

For Questions 1-3 use ASAE Standard D497.4

Question 1.

Consider a 20-foot (6.1 m) wide tandem disk harrow operating 4 inches (10.2 cm) deep at 5.25 mph (8.46 km/hr) in medium soil. Determine the following:

- a) Specific draft.
- b) Drawbar power required.
- c) Required axle power of tractor. Assume tractive efficiency is 0.75.

Question 2.

TRACTOR/IMPLEMENT MATCHING. You are to advise a farmer about the size of a moldboard plow and a tandem disk harrow for a John Deere 4555 tractor. Nebraska Tractor Test 1629 shows the 2-wheel drive tractor developed 156.83 pto hp (116.95 kW) maximum at rated engine speed of 2200 rpm. The hi-idle engine speed (no-load) is 2388 rpm. Available gear ratios provide no-load ground speeds (2388 engine rpm) of 4.71 mi/hr (7.58 km/h) in fourth, 4.83 mi/hr (7.77 km/h) in fifth, 5.53 mi/hr (8.90 km/h) in sixth, 5.97 mi/hr (9.61 km/h) in seventh, 7.02 mi/hr (11.30 km/h) in eighth, and 8.5 mi/hr (13.68 km/h) in ninth.

The soil texture for both moldboard plowing and disking is medium. The disk is to be used for secondary tillage.

- a). What size moldboard plow should I purchase for the tractor? Assume plow bottoms are available only in widths of 18 inches (45.72 cm).
- b). In what gear do you recommend I pull the plow and what will be the actual ground speed assuming that the tractor is operating at 15% slip?
- c). What size tandem disk (width) should I purchase?
- d). In what gear do you recommend I pull the disk and what will be the actual ground speed assuming that the tractor is operating at 15% slip??

Question 3.

You are designing a single pass seedbed preparation and planting unit. The system consists, (i) a set of flouted disk coulters to prepare a 15 cm (6") seedbed (ii) a small roller/packer to firm the seedbed prior to the planter, and (iii) a row crop planter with all the necessary fertilizer and insecticide attachments.

- a) Determine the draft required for this single pass unit for a 12 row planter (30 inch rows), and determine the size tractor (Engine Hp) required to pull this unit. Justify all answers.
- b) Design what you feel would be the best combination of single pass seedbed preparation and planting unit (No other tillage is used in the field). Explain and justify why you include each unit in the system and calculate the draft requirement and tractor power required.

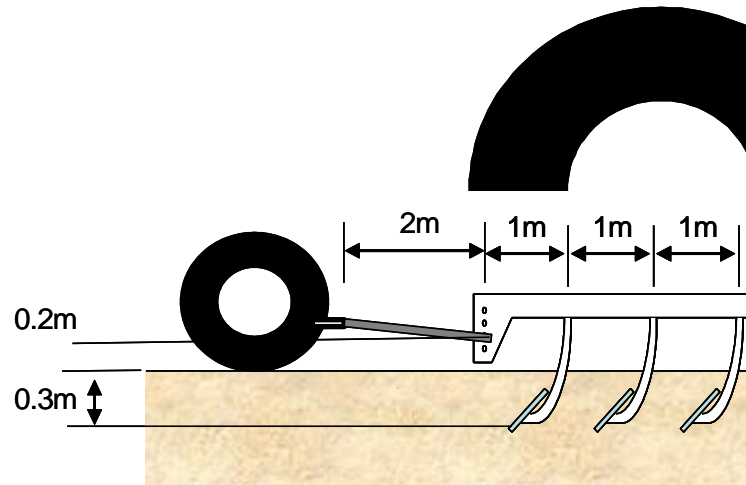

Question 4: The following implement consists of three rows of tines 1m apart. The implement is 12 tines wide. The tractor operates at 9 km/h.

Each tine is 25 cm wide and operates at a depth of 30 cm. The tine is inclined at an angle of 30 degrees from horizontal. The effective length of the tine is 20cm. The tine operates in a soil with a bulk density of 1200 kg/m^3 . The internal friction angle (Φ) of the soil is 30 degrees and the cohesion (c) of the soil is 100 Pa. The soil/metal friction coefficient is 0.3 and the soil/metal adhesion is 25 Pa.

Ignoring any cutting force and any draft effect of the supporting shank, determine the following for a single tine.

- i). The total draft force and specific draft for a single tine.
- ii). The vertical force of the tine.