

TRACTION AND WEIGHT TRANSFER

OBJECTIVES: To become familiar with factors affecting drive wheel slip, drawbar pull, and weight transfer in farm tractors.

EQUIPMENT: Two-wheel drive garden tractor, drawbar load sled, drawbar pull meter, tape measure, stopwatch, and large scales.

PROCEDURE:

1. With an operator on board, record the weight supported by the front and rear wheels of the tractor. Repeat step 1, with a different operator and no operator. The first operator will be the operator for all rep 1 results, and the second for all rep 2 results.
2. Select a suitable forward gear and, with the throttle wide open, operate the tractor with no drawbar load and record the distance and time required for 10 drive wheel revolutions.
3. Attach load sled to tractor, add weight, and for the same throttle, gear, and number of wheel revolutions, note and record distance traveled, time and drawbar force required. Repeat Step 3 for each load, to obtain a second rep under load conditions.
4. Keep repeating step 3, adding weight until the tractor can no longer move the load.
5. Repeat Step 2 - 5, for the second operator to obtain a another rep.

RESULTS:

1. Recall that Power = Force x Velocity. Calculate drawbar (DB) power for each run.
2. Using the dimensions given for the tractor and hitch, and the values of Y_1 and Y_2 , determine the amount of weight transfer, ΔR_1 , occurring under each loading condition. Calculate the weight transfer to rear wheels (ΔR_1), from the drawbar force (P), moment arm (Y_2), and tractor wheelbase (X).
3. Determine the dynamic rear axle force for each run, given the static rear axle weight (determined in step 1 of the procedure) and weight transfer, to determine effect of pull values of each run on dynamic rear axle weight.
4. Using the distances measured for wheel advance, determine the travel reduction (% slip) occurring at each load, where
5. Did maximum DB power occur at slip values predicted? Under what conditions did

$$\text{Travel reduction (\%)} = \frac{\text{NoLoad Advance} - \text{Loaded Advance}}{\text{NoLoad Advance}} \times (100\%)$$

max. pull occur?

6. Using values for weight transfer calculate and tabulate Dynamic Rear Axle Weight (DRAW) where DRAW = SRAW + Wt. Transfer. (SRAW = Static Rear Axle Wt. with operator.)
7. Calculate and tabulate the dynamic traction ratio (DTR). where:

$$DTR = \frac{\text{DrawbarPull}(lbs)}{DRAW}$$

8. Plot drawbar pull and drawbar power vs. Travel Reduction (or % slip) by rep. That is keep the curves for rep1 and rep2 separate.
9. Plot DTR vs. Travel Reduction (or % slip) by rep. That is keep the curves for rep1 and rep2 separate.
9. In your discussion,
 - a) Explain why the time for each run is approximately constant.
 - b) Compare power obtained with manufacture's engine rating (12 Hp) to the tractor's drawbar power. Comment and explain why the drawbar power does not approach the rated engine power. Comment and explain at least two things that could be changed to increase drawbar power closer to rated engine power.
 - c) Explain why curves plotted for items 7 & 8 are shaped as they are. Also discuss whether slip-pull and power-slip limits obtained agree with values predicted (See curves on handout).
 - d) Explain why maximum power does not occur at either max. ground speed or at max. DBpull.

- e) Explain any unusual results.
- f) Comment on the errors associated with these measurements.

Weight and Dimensional Data

Dimension	A.C. 312	Ford 125	Deere 214	WH C-141
X	48.10	46.00	46.00	45.50
h_1	9.30	9.17	10.89	
h_2	2.50	2.50	2.50	2.50
h_3	$x \tan \Theta$	$x \tan \Theta$	$x \tan \Theta$	$x \tan \Theta$
h_4	8.00	8.25	9.50	7.50
l_1	$h_4/\tan\Theta$	$h_4/\tan\Theta$	$h_4/\tan\Theta$	$h_4/\tan\Theta$
l_2	12.00	8.00	9.50	11.00
l_4	40.50	40.50	40.50	40.50
Θ	8.00°	8.37°	10.21°	7.21°
$Y_1(Y_r)$	9.59	9.32	11.18	8.82
$Y_2(Y_f)$	16.28	16.02	19.33	14.53
To. Wt. w/oper				
R_r (without oper.)				
R_r (without oper.)				
R_r (with oper 1.)				
R_r (with oper 1.)				
R_r (with oper 2.)				
R_r (with oper 2.)				

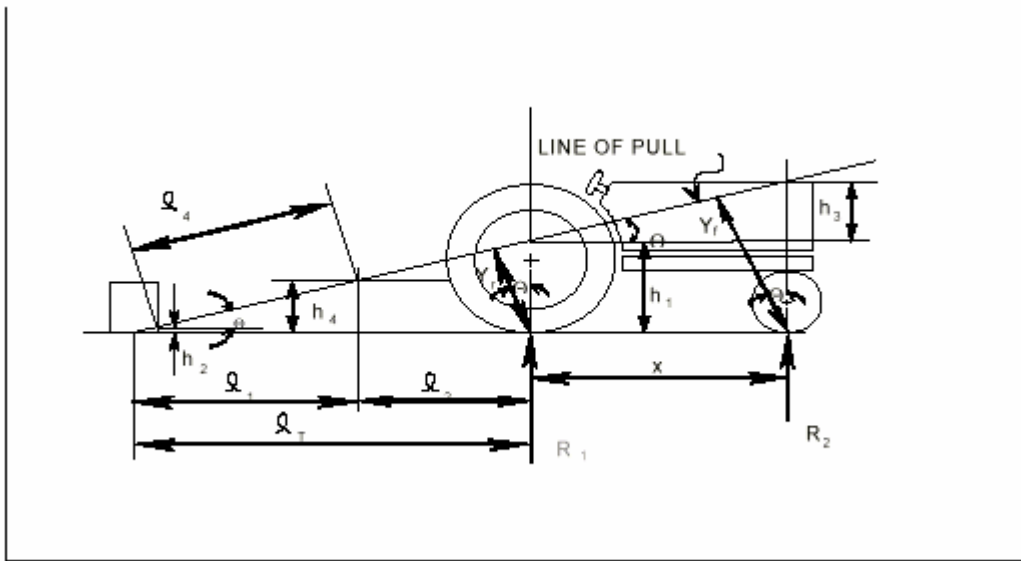

Traction Testing: Observed Data

Run #	Rep	Weight Added to the Sled				Cylinder Load		Distance Traveled m, ft	Time Sec.
		Number: Large Weights	Number: Small Weights	Number: Other Weights	Total Weight lbs.	Pressure, PSI	Pull, lbs.		
1	1	No Load (Withouth Sled)			0				
2									
3									
4									
5									
6									
7									
8									
9									
10									
11									
12									
13									
14									
15									
16									
17									
18									
19									
20									
1	2	No Load (Withouth Sled)			0				
2									
3									
4									
5									
6									
7									
8									
9									
10									
11									
12									
13									
14									
15									
16									
17									
18									
19									
20									

Height of Hitch _____

Distance of Hitch from rear axle _____

Weights: Small 20 kg, 45 lbs
 Large 63 kg, 140 lbs
 Special 12.6 kg, 28 lbs
 Sled 100 kg, 225 lbs

