

GEAR TRANSMISSIONS

OBJECTIVE:

To acquaint the students with various forms of tractor power trains. The student is expected to be able to identify and describe the components of these units and to determine the gear ratio involved.

THEORY:

One method of determining ratios of series or compound gearsets is to establish the ratio of input to output speed. However, this is somewhat difficult unless the unit can be driven by a power source so that a tachometer can be used. A more practical exercise is to count the teeth on mating gears. For example: the gear on an input shaft has 10 teeth and mates with an output gear having 18 teeth. The ratio is 18/10 or 1.8 to 1; that is, the input shaft must turn 1.8 revolutions for each revolution of the output shaft. In the case of compound gearsets, the ratios for individual mating pairs are multiplied together to obtain an overall ratio.

Determining ratios for planetary gears is complicated by the relative motion of gear components that occur under certain conditions.

Let $N = \text{RPM}$
 $T = \text{No. teeth}$

$r = \text{ring gear}$
 $s = \text{sun gear}$
 $c = \text{carrier}$

Then:

1. for ring gear fixed, $N_s/N_c = T_r/T_s + 1$
2. for carrier fixed, $N_s/N_r = -T_r/T_s$
3. for sun fixed, $N_r/N_c = T_s/T_r + 1$
4. no fixed gears, $(N_r - N_c) / (N_s - N_c) = -T_s/T_r$

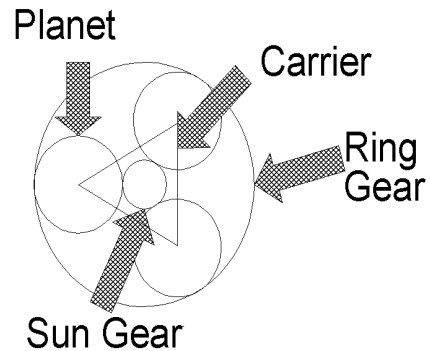

LAB QUESTIONS:

For each of the power train units supplied, determine the ratios for all gear selections. Data sheets are supplied for recording the necessary information. Answer all questions and work the accompanying problem. Note that schematic diagrams and tooth numbers are given on the last page of this exercise for transmission units one and four. In addition, remember to enter **all** ratios as input to output ratios.

- A. Using the corresponding diagram from page 8 determine the ratios for each gearshift position of the IH transmission.

UNIT 1 - IH SUPER H (TRANSMISSION PORTION ONLY)				
GEARSHIFT POSITION	NO. TEETH (Output/Input)			Overall Gear Ratio
	Input Pair	Idler Pair(s)	Output Pair	
1	/		/	
2	/		/	
3	/		/	
4	/		/	
5	/		/	
REV	/	/	/	
PTO	/		/	

- B. For Unit 1 also determine:
- Is the arrangement a parallel-shaft or an in-line shaft arrangement?
 - Is it a sliding-gear or constant-mesh transmission?
 - Type(s) of gear teeth used?
 - Is the transmission synchronized?
 - (a) If synchronized, what type of synchronizers are used?
(b) If synchronized, which speeds are synchronized?
 - Determine and record the ratio between the transmission and the differential:
 - Determine and record the ratio between the output of the differential and the rear axle. (Final drive ratio)
 - If one wheel is locked with the brake, does the other wheel turn faster than, slower than, or the same as it would if both wheels were free to turn? If faster or slower, how much so?

C. For Unit 2 (IH torque amplifier) determine:

1. What type gear train is used to obtain reduction?
2. The ratios between input and output? (fill out chart)

GEAR	NO. TEETH	
	HIGH RANGE	LOW RANGE
INPUT GEAR		
1st INTERMED. GEAR		
2nd INTERMED. GEAR		
OUTPUT GEAR		
OVERALL RATIO		

3. Write below a specific explanation of how power is transmitted through the "TA" when it is in:
 - a) HIGH RANGE

b) LOW RANGE

4. If Unit 2 ("TA") were installed in the driveline between the engine and the Unit 1 transmission, what would the gear ratio be between the engine and the output of the transmission with the torque amplifier in low range and the transmission in third gear?

Ratio -

D. Observe Unit 3 (PTO reduction)

1. What type of gear train is used?
2. Determine the reduction ratio:
3. Briefly describe the operation and power flow through the system (Input end is the blue shaft) when the PTO shaft is:
 - a) engaged:
 - b) disengaged:
4. For a clockwise input rotation, what direction does output rotate?
5. How many teeth are on the:
 - sun gear -
 - planet gear -
 - ring gear -What type of teeth are used?
6. Calculate the input RPM required to obtain a 540 RPM output.

Input RPM =

E. For Unit 4 use the schematic diagram and color coding scheme at the end of this lab to determine the ratios for each of transmission speeds.

UNIT 4 FORD 4000 8-SPEED							
Gear	NUMBER OF TEETH (Output/Input)					OVERALL RATIO	
	Input Pair	Intermed. Pair (?)	Intermed. Pair (?)	Intermed. Pair (?)	Output Pair	High Range	Low Range
1	/	/	/	/	/		
2	/	/	/	/	/		
3	/	/	/	/	/		
4	/	/	/	/	/		
5	/	/	/	/	/		
6	/	/	/	/	/		
7	/	/	/	/	/		
8	/	/	/	/	/		
Rev Low	/	/	/	/	/		
Rev High	/	/	/	/	/		

Note: Not all gear shift positions have intermediate gears

F. Also for Unit 4

1. Is the transmission a parallel-shaft or an in-line shaft arrangement?
2. Is it a sliding-gear or constant-mesh transmission?
3. Type(s) of gear teeth used?
4. Is the transmission synchronized?
5. (a) If synchronized, what type of synchronizers are used?
 (b) If synchronized, which speeds are synchronized?

FORD 4000 DIFFERENTIAL

This unit is the differential gear assembly from a Ford 4000 tractor. It receives its power from the transmission (Unit 4) and transfers it to the final drive assembly (Unit 6) located in the axle housing. Special problems are introduced in this assembly since the power is directed around a 90 degree corner and then divided between the two drive wheels. In addition to transferring power, the differential also allows the rear wheels to turn at different speeds (such as cornering). These functions are accomplished by means of a beveled ring and pinion gear set and a four-gear "spider" assembly.

G. For this unit determine the following:

1. Is the speed changed?
2. If so, is it increased or decreased?
3. What is the gear ratio?
4. What type of gears are used?
5. This unit also features a device to lock both of the axles together. Why would the operator find this desirable?
6. Of what purpose does the small cylinder on the lock serve?
7. Why is the cylinder necessary?
8. Will the lock, once engaged, release automatically? If so, what operating conditions will cause automatic release?

What other ways can locks be released?

UNIT 6
FINAL DRIVE UNIT

This unit is the final drive unit from a Ford 4000 tractor. It receives its power from one side of the differential assembly and transmits it to the drive wheels. To do this it uses a planetary gear system.

The planetary gear cluster gets its name from the three components of the system. They are the sun gear (center), the planets (mounted on a single carrier), and the ring gear (outer).

To use the cluster, any one of the three components is held stationary. The remaining two components then become the input and output. By locking two components together, the entire cluster will act as one unit with no change in direction of rotation or speed. This supplies us with a variety of gear ratios in a relatively small package. In this unit, however, only one of these ratios is used.

H. For unit 6 determine:

1. Which component is used as the input?
2. Which is the output?
3. Is there a stationary component? If so, which?
4. Is the speed reduced or increased?
5. What is the ratio?
6. Is there a change in rotation direction between the input and output?

Explain.

PROBLEM USING FORD DRIVE COMPONENTS:

Assume an unloaded outside tire with a diameter of 57.1 in. at normal inflation pressure is used. This tire is mounted on the axle of Unit 6 which, in turn, is driven by Units 5 and 4, respectively. When operating under load the tire deflects 5.5 cm below the unloaded radius. The engine is delivering 46.9 hp at 2200 rpm to the transmission input shaft. See diagram below.

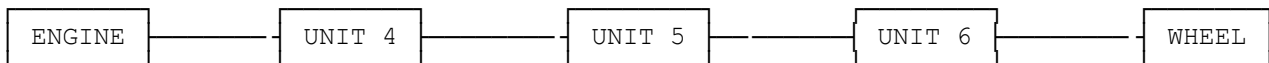

Assume efficiencies of 98% each for transmission, differential, and final drive. Wheel slippage may be ignored.

DETERMINE:

1. Ground speed in mph and axle torque in the right axle in ft-lb when transmission is in first gear and moving straight forward.
2. Repeat part 1 for seventh gear.
3. Discuss the relations between torque and speed when power is constant between input and output of a gear train. Also discuss the effect of power train efficiency on speed and torque in a gear train.

**UNIT 1 - IHC SUPER H
TRANSMISSION
(Shown in the neutral Position)**

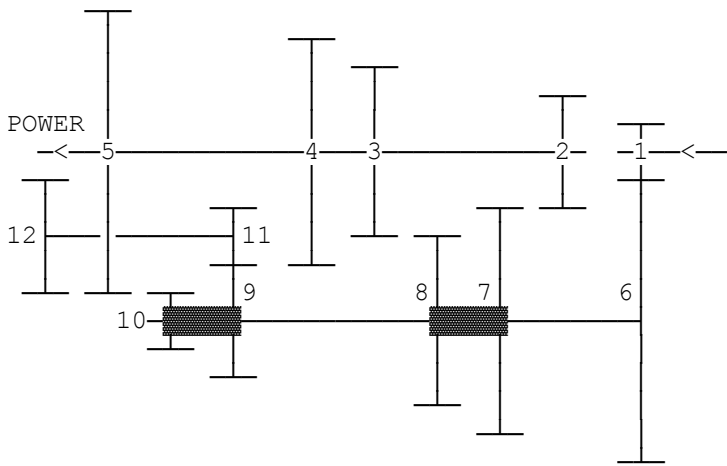

GEAR	TEETH
1	18
2	31
3	36
4	41
5	47
6	55
7	39
8	34
9	29
10	23
11	22
12	22

UNIT 4 - FORD 4000 8-SPEED TRANSMISSION

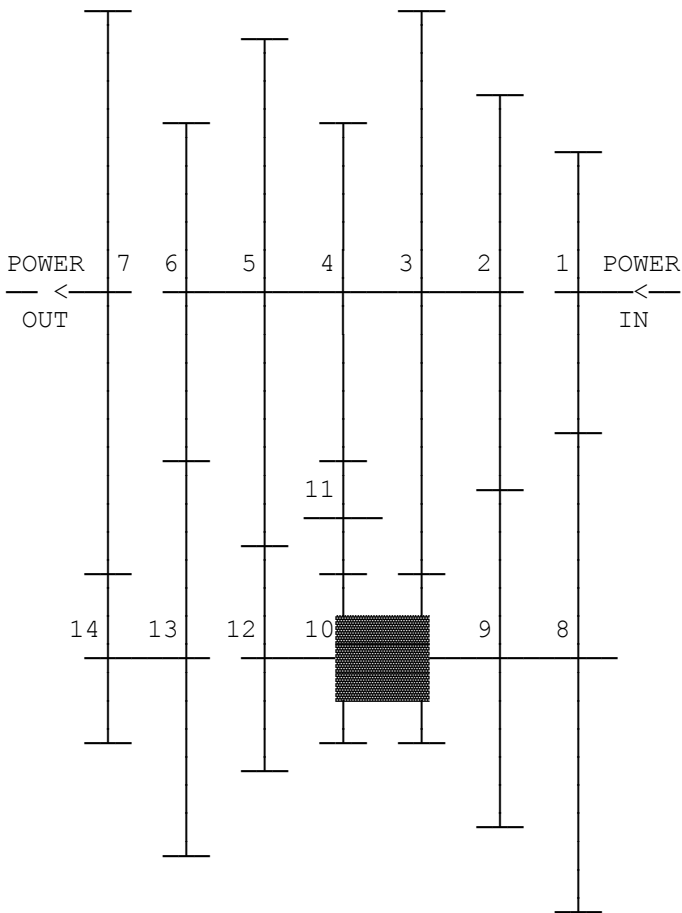

GEAR	TEETH
1	29
2	35
3	46
4	32
5	43
6	30
7	49
8	46
9	30
10	18
11	31
12	21
13	35
14	16

Gears 1 & 8 are used in all speeds
Gears 7 & 14 are used in all low
range speeds, exclusively.

1st & 5th.....Red	1	2	4	LOW
2nd & 6th.....Blue				
3rd & 7th....Yellow				
4th & 8th..No color				
Reverse.....White				
	3	R		HIGH

= Common Hub